

REVISIONS					
REV	ECO	DESCRIPTION	DATE	BY	APPR
A1	-	PERLIMINARY DESIGN	25/OCT/14	ORION	TOMMY

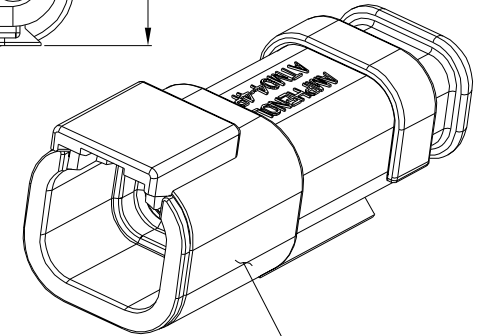

STANDARD MOLDED COLOR IS GREY.  
ADDITIONAL COLORS SHOWN IN PART NUMBER  
CHART ARE AVAILABLE VIA SPECIAL ORDER.

REQUIRES CONTACT  
RETENTION WEDGE AWM-4P

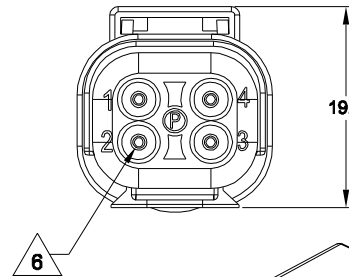
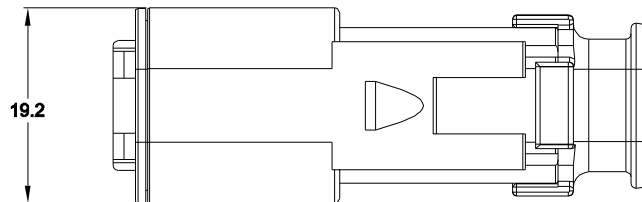
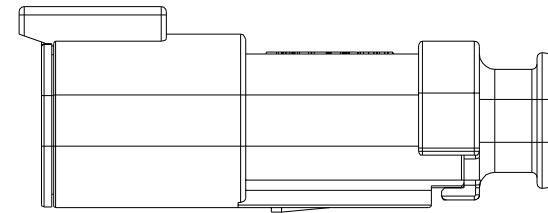
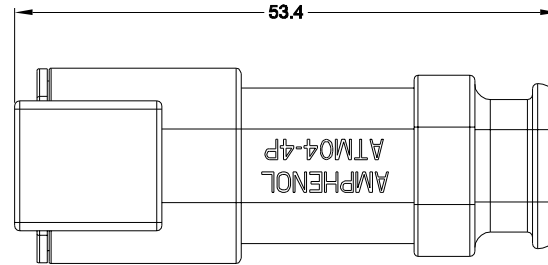
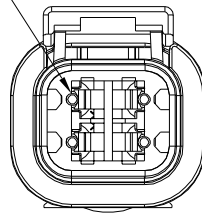

NOTES: UNLESS OTHERWISE SPECIFIED

- MATERIAL:  
HOUSING: THERMOPLASTIC  
SEAL: SILICONE RUBBER
- MODIFICATIONS: STRAIN RELIEF END CAP
- SPECIFICATIONS:
  - CURRENT RATING: 7.5 AMPS
  - OPERATING TEMPERATURE: -55°C TO +125°C
  - DIELECTRIC WITHSTANDING VOLTAGE: LESS THAN 2 MILLIAMPS CURRENT LEAKAGE @ 1500 VOLTS AC.
  - INSULATION RESISTANCE: 1000 MEGOHMS MIN @ 25°C.
  - MOISTURE RESISTANCE: IP67 ( MATED CONDITION )
  - MATING CYCLE DURABILITY: 100 CYCLES
  - RoHS COMPLIANT
- MATING PART: ATM06-4S\* PLUG  
(\* = MODIFICATIONS AND COLORS)
- ALL DIMENSIONS ARE FOR REFERENCE USE ONLY.

6 CONTACT SIZE AND REAR SEAL WIRE RANGE:

CONTACT SIZE	MIN. INSUL O.D.	MAX. INSUL O.D.	TYPICAL WIRE RANGE
20	1.35 mm (.053 in)	3.05 mm (.120 in)	16 - 22 AWG

PART NUMBER CHART	
COLOR	PART NUMBER
GREY	ATM04-4P-SR01GY
BLACK	ATM04-4P-SR01BK
BLUE	ATM04-4P-SR01BL
BROWN	ATM04-4P-SR01BN
GREEN	ATM04-4P-SR01GN
RED	ATM04-4P-SR01RD
WHITE	ATM04-4P-SR01WT
YELLOW	ATM04-4P-SR01YL

SEE PART NUMBER CHART		DESCRIPTION		ITEM
QUANTITY	PART NUMBER			
<p>UNLESS OTHERWISE SPECIFIED</p> <p>1) All dimensions are in metric (mm).</p> <p>2) Tolerances are as follows:</p> <p>1 PL DEC ±0.30 Fractions ±1/64</p> <p>2 PL DEC ±0.16 Angles ±1°</p> <p>3 PL DEC ±0.08</p> <p>3) Note reference = </p>				
SIGNATURES		DATE		
DRAWN: ORIONLI		25/OCT/14		
CHECKED:		ENGINEER:		
APPROVAL:		CUSTOMER:		
MATERIAL SPECIFICATIONS:		<p>THIS DRAWING IS SUPPLIED FOR INFORMATION ONLY. DESIGN FEATURES, SPECIFICATIONS AND PERFORMANCE DATA SHOWN HEREON ARE THE PROPERTY OF THE AMPHENOL CORPORATION. NO RIGHTS OF REPRODUCTION ARE IMPLIED. ALL DIMENSIONS ARE SUBJECT TO NORMAL MANUFACTURING VARIATIONS.</p>		
PROCESS SPECIFICATIONS:		<p>SIZE TYPE DWG NO: <b>B C- ATM04-4P-SR01XX</b> REVISION <b>A1</b></p>		
NEXT ABBY:		SCALE: NONE SHEET 1 OF 1		

TITLE: RECEPTACLE, 4 PIN, STRAIN RELIEF, ATM SERIES  
DWG NO: ATM04-4P-SR01XX  
REV: A1  
SH: 1  
OF: 1